

# Production of Rotary LED Display

Kao-Feng Yarn<sup>1</sup>, Wen-Bin Lin<sup>2</sup>

<sup>1,2</sup>Department of Semiconductor Engineering,  
CTBC University of Technology, Taiwan 744, ROC

Corresponding Author: Wen-Bin Lin

DOI: <https://doi.org/10.52403/ijrr.20260456>

## ABSTRACT

In order to reduce the amount of paper used for environmental protection, we made this attractive signboard to reduce the amount of paper used and tree felling. Also, the infrared remote control can be used to change the designed text and graphics, thus achieving the goal of convenience, time-saving and safety. This hardware production mainly utilizes the characteristics of the persistence of vision principle to generate images. Using 8051 series (STC12C5A32S2) SoC, it allows a row of LEDs to flash different LEDs at different times. The principle is similar to that of a movie's continuous picture. Together with the high-speed rotation of the motor, it creates the persistence of vision to hold on the human eye and displays the screen we requested.

**Keywords:** Persistence of vision, 8051 series SoC, STC12C5A32S2

## 1. INTRODUCTION

Light sticks, also known as glow sticks, have become a well-established entertainment product in today's society. They are commonly seen at concerts, where fans rapidly wave the glowing rods in their hands. As they move, the light trails form words or patterns, creating a dazzling and novel visual effect. What seems magical is actually quite simple in principle—it's essentially a flickering light source. As this

light passes before the human eye, it creates a linear display image. This occurs due to the eye's "persistence of vision" effect, allowing meaningful visual patterns to form before our eyes.

Rotating LED displays can reduce energy waste and significantly enhance the cost-effectiveness of electronic signage or displays, and digital signage has advanced remarkably in recent years. In today's society, achieving the same effect with the fewest components while minimizing electrical energy loss is paramount. Using a minimal number of LED lights can produce brightness comparable to conventional fluorescent tubes, while also offering greater versatility [1-3].

## 2. THEORETICAL FRAMEWORK

### 2.1 Persistence of Vision (POV)

After the human eye observes an object, its image lingers on the retina for a very brief moment. During this fleeting interval, when the preceding visual image has not yet fully faded and a new visual image begins to form, a continuous visual illusion emerges in the brain. In fact, we can experience this particularly fascinating and unique physical phenomenon at any time.

Further research reveals that the human visual persistence lasts approximately 1/24th of a second. This duration is not a fixed standard, as it varies based on individual differences among observers and the brightness and size of the observed object. Modern cinema capitalizes on this

phenomenon by filming and projecting at 24 frames per second. This technique creates a series of static, sequential images that, when viewed by the human eye, produce a continuous illusion of motion [1-4].

## 2.2 Overview of POV Display Production

By leveraging the principle of persistence of vision, we can generate a series of residual images from the movement of light sources, creating a magical, dreamlike display effect that appears to float in midair.

## 2.3 Light-Emitting Diodes

Due to their high brightness, rich colors, long lifespan, impact resistance, low power consumption, simple operation, and low operating voltage, LEDs (light-emitting diodes) have become the preferred light source for visual persistence displays.

## 2.4 Motion Mechanisms

Different motion mechanisms of light sources produce various display patterns through visual persistence. Light sources mounted on clock-hand-style rotating bodies create circular display screens through rotation. As shown in Figure 1, this involves circular disc-shaped rotational motion.

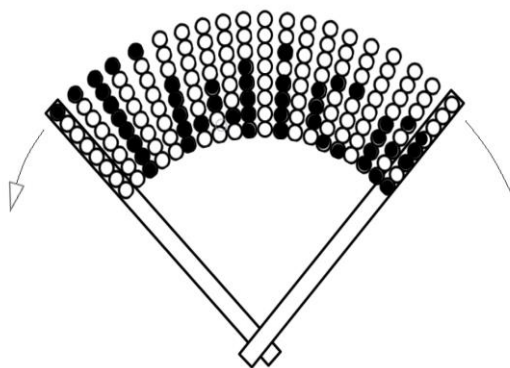

Figure 1: Circular Rotational Motion

### Features of this method:

(1) Since the light source's rotational speed remains constant, the displayed pattern remains consistent. However, font variations are more pronounced when displaying text, particularly near the center of the circle. To prevent distortion of displayed fonts and patterns, specialized software is required to

perform coordinate transformation on the light points.

(2) The vibration phenomenon during production adjustment is easy to control. This motion method achieves the following effects:

① Persistence of vision display on the rotating wheel

② Persistence of vision display on the fan

③ Dual-mode digital/analog clock display  
Position the light-emitting diode parallel to the rotational axis so that the resulting motion forms a cylindrical pattern. This cylindrical rotational motion is illustrated in Figure 2.

### Characteristics of this method:

(1) The rotational speed can remain constant, ensuring consistent display patterns where both text and graphics appear unchanged.

(2) The display surface is flat, typically requiring full-screen observation. This is generally compensated for using scrolling displays (marquee effects).

(3) Visual persistence images produced this way are highly suitable for advertising and can be scaled to large formats.

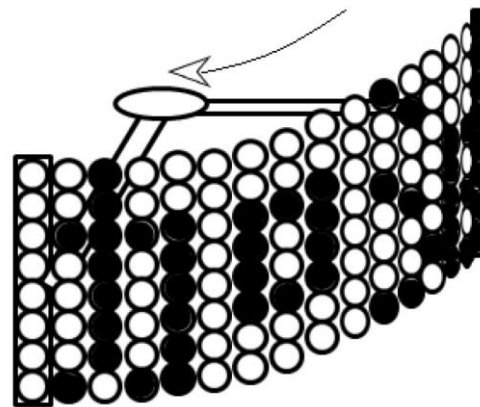

Figure 2: Cylindrical Rotary Motion

## 2.5 Power Supply Method

Inductive power supply transmits energy through inductive coupling, eliminating the need for wired connections between components. Generally speaking, an inductive power supply contains a coil that generates an alternating electromagnetic field when driven by AC power. Within the electrical device, another coil receives this

alternating electromagnetic field and converts it into electrical energy. The received electrical energy is then used to charge the device's internal battery, which in turn powers the device. This is equivalent to placing the primary and secondary coils of a transformer inside the charger and the electrical device, respectively. This device in this paper utilizes inductive power transfer technology for its power supply.

### 2.6 Infrared Control

To adjust and update the display content of the motion-based visual persistence display system, we must also address communication with the system. We employ infrared communication as our method, while more advanced approaches utilize wireless communication, such as transmitting display information to the system.

## 3. CIRCUIT PRINCIPLES

### 3.1 Power Supply Circuit

The power supply circuit shown in Figure 3 consists of the following components:

- (1) J1: Dedicated connector for program transmission
- (2) D50: 5V Zener diode
- (3) L1: Secondary winding
- (4) D51–54: Rectifier diodes

This circuit section functions to supply power to the rotating mainboard. Its operational principle is described as follows: The AC voltage induced by the secondary winding undergoes full-wave rectification through four 4148 rectifier diodes. After voltage regulation via a 5V zener diode, the output is filtered by a 220µF capacitor.

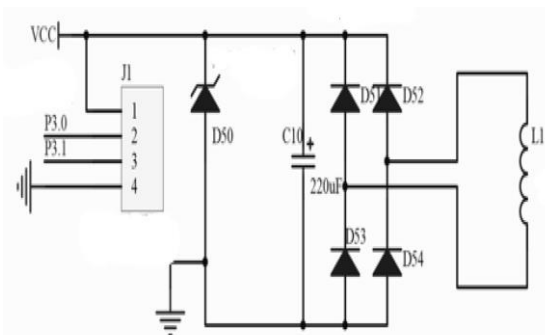

Figure 3: Power Supply Section Circuit

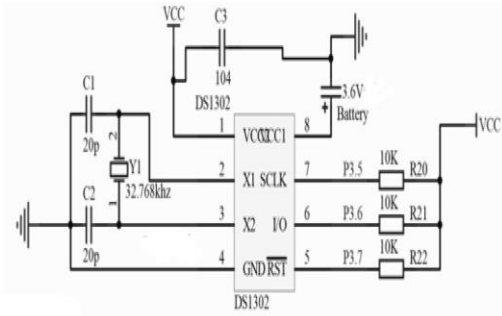

Figure 4: Real-Time Clock Circuit

### 3.2 Real-Time Clock Circuit

The real-time clock circuit shown in Figure 4 consists of the following components, with their operational principles described as follows:

- (1) VCC2: Primary power supply pin. When VCC2 is 0.2V higher than VCC1, the DS1302 is powered by VCC2. When VCC2 is lower than VCC1, it is powered by VCC1.
- (2) X1 and X2: ① Both pins require connection to a 32.768 MHz quartz crystal oscillator to provide precise timing for the DS1302. The negative terminal of this quartz crystal oscillator must be connected to a 20 pF capacitor. ③ If using an active crystal oscillator, connect only X1; X2 may be left unconnected.
- (3) GND: Ground.
- (4) RST: Pin for the DS1302. This pin must be at a high potential when reading from or writing to the DS1302. This pin internally contains a 40kΩ resistor.
- (5) I/O: This pin is a dual-channel signal pin, handling both data reading and writing.
- (6) SCLK: Input pin. SCLK is used to receive the clock signal.
- (7) VCC1: Backup power supply pin.
- (8) Circuit Function: Provides the clock signal.

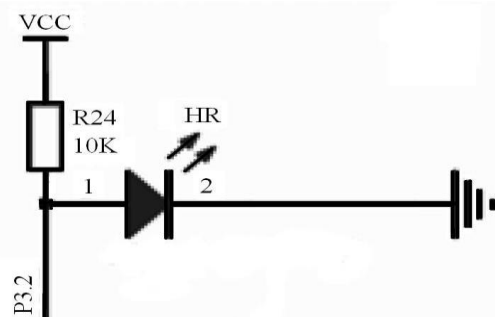

Figure 5: Real-Time Clock Circuit

### 3.3 Infrared Signal Transmission Circuit

The infrared signal transmission circuit shown in Figure 5 consists of the following components, with their operational principles described as follows:

HR is an infrared receiving diode. The longer lead of the infrared receiving diode is the negative terminal, and the shorter lead is the positive terminal. This circuit functions to enable device operation by transmitting infrared signals.

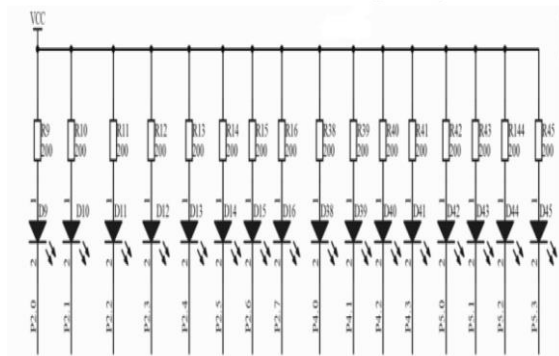

Figure 8: Side View Circuit Diagram for 16 LEDs

### 3.4 Infrared Remote Control Signal Receiving Circuit

The infrared remote control signal reception circuit shown in Figure 6 consists of the following components, with their operational principles described as follows:

- (1) Q1: Integrated infrared receiver module.
- (2) XIN: Signal output.
- (3) GND: Ground connection.
- (4) VCC: 5V power supply.

This circuit functions to receive signals emitted by any button on the remote control using an integrated infrared receiver.

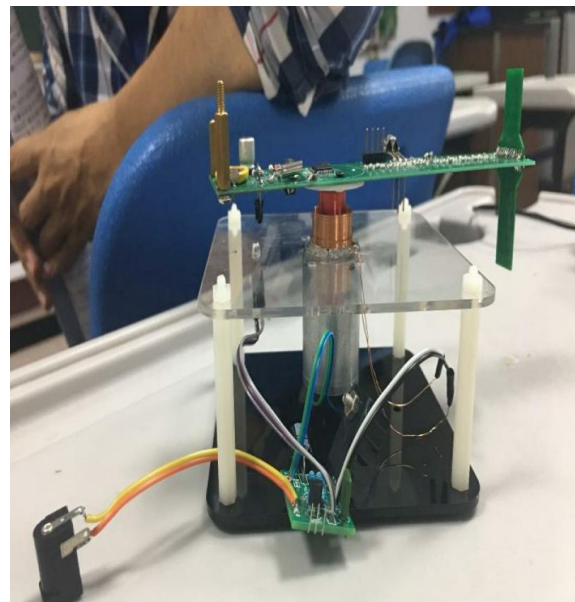

Figure 9: Complete Side View of Finished Product

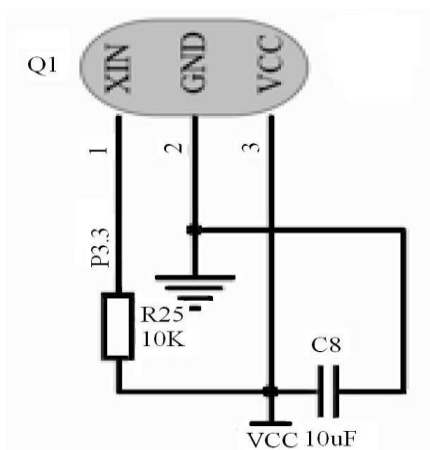

Figure 6: Infrared Remote Control Signal Receiving Circuit



Figure 10: Complete Front View of Finished Product

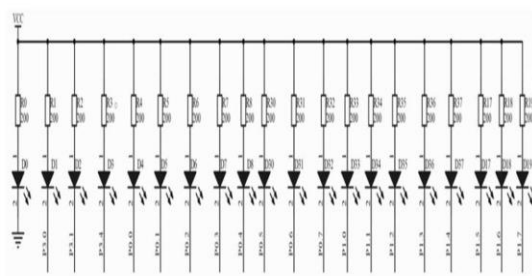

Figure 7: Front View Circuit Diagram for 20 LEDs

## 4. CONCLUSIONS AND HARDWARE IMPLEMENTATION RESULTS

The complete side view of the finished product is shown in Figure 9. The complete front view of the finished product is shown

in Figure 10. The front view during operation is shown in Figure 11. The side view during operation is shown in Figure 12. This paper utilizes LEDs to demonstrate the phenomenon of persistence of vision, creating a rotating LED display device. During the process, to increase rotational speed for clearer character display, the motor requires adjustment. Excessive speed causes excessive vibration and instability, while insufficient speed results in blurred character display. The electronic advertising text display hardware is composed of combinations of 0s and 1s.

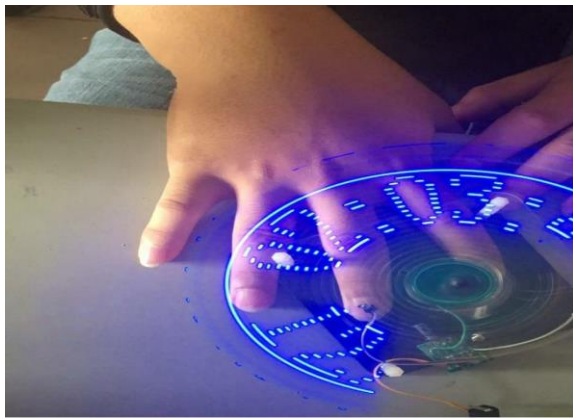

Figure 11: Front View Display During Operation

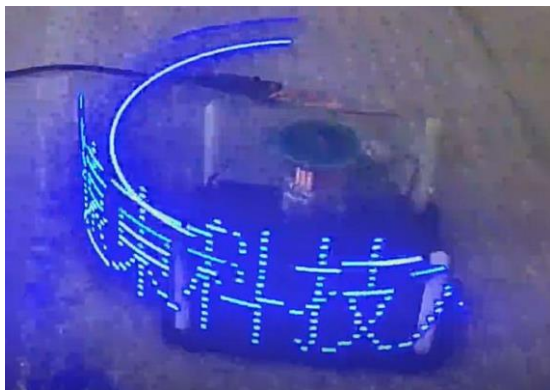

Figure 12: Side View Display During Operation

### Declaration by Authors

**Acknowledgments:** The authors would like to acknowledge Mr. Shun-Chi Wang who constructed much of the hardware for the experimental system.

**Source of Funding:** None

**Conflict of Interest:** No conflicts of interest declared.

### REFERENCES

1. Wiley (1981), "Flat-Panel Video LED Display", *Information Display*, 1981(2), 12, 1981. <https://doi.org/10.1002/j.2637-496X.1981.tb01822.x>
2. Zdravko Karakehayov, Knud Smed Christensen, Ole Winther (2018),"The 8051 Microcontroller", *Embedded Systems Design with 8051 Microcontrollers*, 25 - 54,2018. <https://doi.org/10.1201/9781482276824-2>.
3. Ziyang Wang, Hui Gao (2023), "Design of Vehicle Tunnel Illumination Measurement Device Based on STC12C5A60S2 Single-Chip Microcomputer", *Electronics*, 12(2),443, 2023. <https://doi.org/10.3390/electronics12020443>
4. Wen-Bin Lin, and Kao-Feng Yarn (2025), Random Variable LED Dice Roll Implementation, *International Journal of Research and Review (IJRR)*, 12(2), 84- 88. <https://doi.org/10.52403/ijrr.20250210>

How to cite this article: Kao-Feng Yarn, Wen-Bin Lin. Production of rotary LED display. *International Journal of Research and Review*. 2026; 13(4): 547-551. DOI: <https://doi.org/10.52403/ijrr.20260456>

\*\*\*\*\*